

NEW



PRECISION DIAPHRAGM CHUCK
VMCHP



Precision Diaphragm Chuck VMCHP

Modern grinding machines require matching workholding systems to fully exploit the machines' potential and to ensure that the workpieces are manufactured efficiently.

Worldwide, SwissChuck is second to none when it comes to high-precision chucks. The very close collaboration with renowned machine tool builders and our continuous drive for innovation are the foundation of our technological leadership. For this reason, SwissChuck products offer the user the highest level of precision, reliability and flexibility in application.

The pneumatically actuated diaphragm chuck family 6VMCHP guarantees clamping of workpieces at the highest level of precision and delivers a repeatability of ≤ 0.002 mm. During clamping, the pull-back effect of the diaphragm ensures that the workpieces are pulled back against the end-stop, which, in turn, ensures that tight linear tolerances can be maintained reliably during the whole manufacturing process.

A through bore allows the supply of coolant, purge air or room for a part presence checking probe in the center of the chuck. The pneumatic rotary feed device fits through the spindle and can be screwed directly into the chuck body.

Advantages



- High precision ≤ 0.002 mm
- Opening stroke suitable for automatic loading
- Axial end-stop mounted directly on chuck body offering absolute stability
- Coolant supply via central bore (through hole)
- Precision interfaces for top jaws; no need for regrinding the clamping section
- Pull-back effect

Function



- Pneumatically actuated on front-end
- Hermetically sealed against contamination

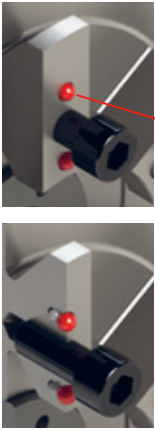

Precision interfaces with ball positioning



Suitability according to machining process:

- A**
Cylindrical grinding
- B**
Eccentric cylindrical or orbital pin grinding
- C**
Turning
- D**
Hard turning
- E**
Combination Grinding/hard turning



Explanation of symbols:
SwissChuck.com

VMCHP

Type	Item No.	Outside ø [mm]	Height [mm]	Max. RPM [1/min]	Weight [kg]	Actuation max. [MPa]	Suitable for
6VMCHP 85	SX1007477	85	38	5000	1.35	6	AB(CDE)
6VMCHP 128	SX1007621	128	58	3500	4.04	6	AB(CDE)
6VMCHP 160	SX1007643	160	73	2250	8.16	6	AB(DE)
6VMCHP 200	SX1007661	200	91	1500	15.7	6	AB(DE)

EXAMPLES OF APPLICATIONS

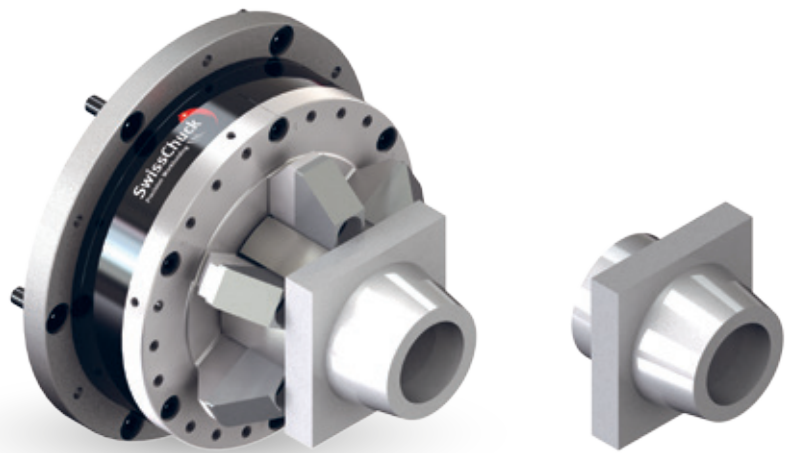

6VMCHP 200

Injection mold insert:

Clamping on outside diameter

- Grinding of bore and taper
- Extremely tight axial tolerances
- Highest concentricity of ID to OD

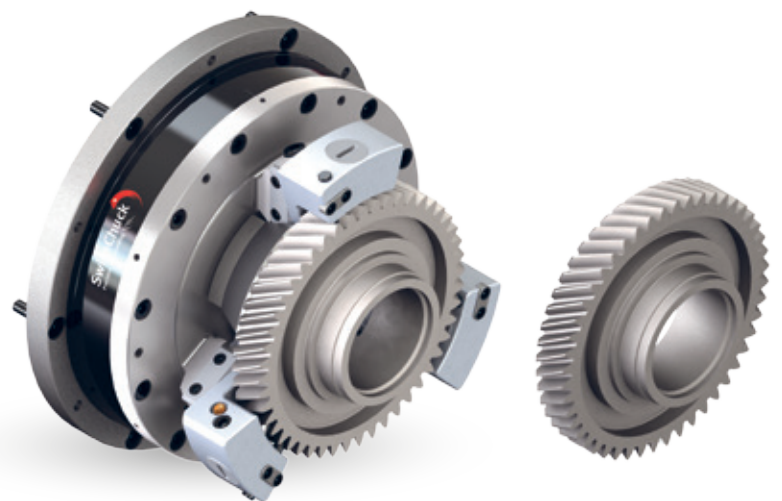

3VMCHP 240 So

Helical gear:

Clamping in the pitch circle, with pull-back onto axial end-stop

- Grinding of the bore and the outside diameter
- Fast changeover of jaws due to radially accessible mounting bolts
- Compensation by means of pendulum jaws
- With radially adjustable pro-centering pins

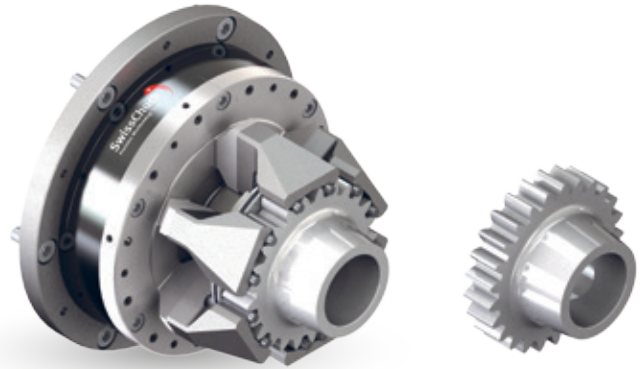

6VMCHP 160

Spur gear

Clamping in the pitch circle, with pull-back onto axial end-stop

- Grinding of the bore and the taper
- Excellent concentricity of bore and taper to the pitch circle
- Very tight linear tolerances; perfect pull-back onto axial end-stop
- Coolant supply via central through bore



6VMCHP 85 S0

Small component

Outside clamping of $\varnothing 7.5 / 3.5 \times 5.8$ with pull-back onto axial end-stop

- Grinding of the bore and the faces
- Very tight linear tolerances; perfect pull-back onto axial end-stop
- Coolant supply via central through bore

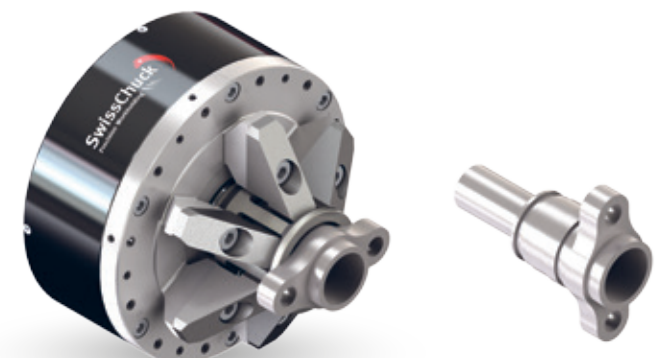

6MCHP 160 S0

Fuel injection body

Outside clamping with pull-back onto axial end-stop

- Grinding of the bore and the faces
- Very tight linear tolerances; perfect pull-back onto axial end-stop
- Coolant supply via central through bore
- Pneumatic cylinder actuated special solution

ACCESSORIES VMCHP

Diaphragm VMCHP

Diaphragms

Type	Item No.
6VMCHP 85	SM1007478
6VMCHP 128	SM1007622
6VMCHP 160	SM1007644
6VMCHP 200	SM1007665

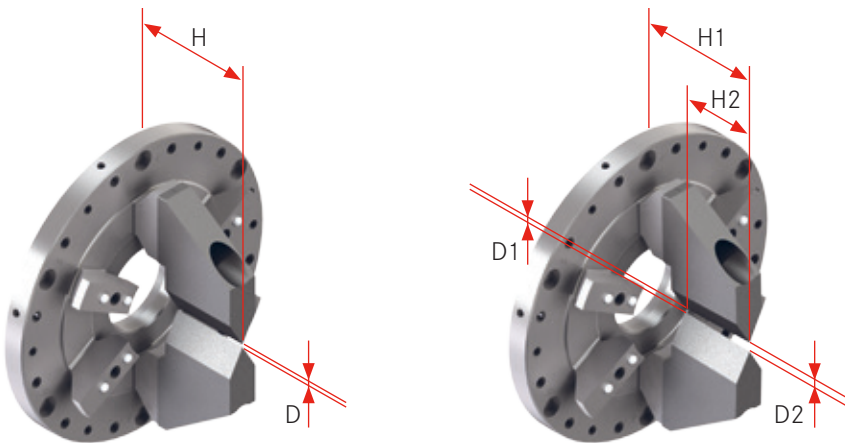

Opening strokes

Type	H [mm]	H1 [mm]	H2 [mm]	D [mm]	D1 [mm]	D2 [mm]
6VMCHP 85	41	41.9	20	0.5	1.3	2.5
6VMCHP 128	62	63.3	33	0.5	0.8	2.7
6VMCHP 160	78	79.6	43	1	1.1	3.4
6VMCHP 200	97.5	99.5	55	2	2.3	5.2

Top Jaws VMCHP

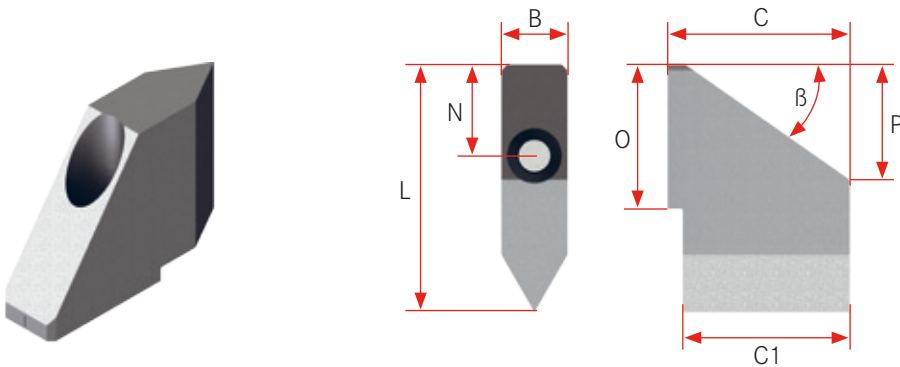

Soft top jaws (set of six pieces – Material CK 45)

Size	Designation	Item No.	Width B [mm]	Height C [mm]	Height C1 [mm]	Length L [mm]	P [mm]	β [°]	O [mm]	N [mm]
85	6VMCHP-WBCK 85	SM1007481	9	25	20	34.75	9	25	20	11
128	6VMCHP-WBCK 128	SM1007630	14	38	33	52.75	14	38	30.5	19
160	6VMCHP-WBCK 160	SM1007650	17	48	43	65.5	17	48	38	24
200	6VMCHP-WBCK 200	SM1007666	22	60	55	81.5	22	60	47.5	30

MOUNTING EXAMPLES

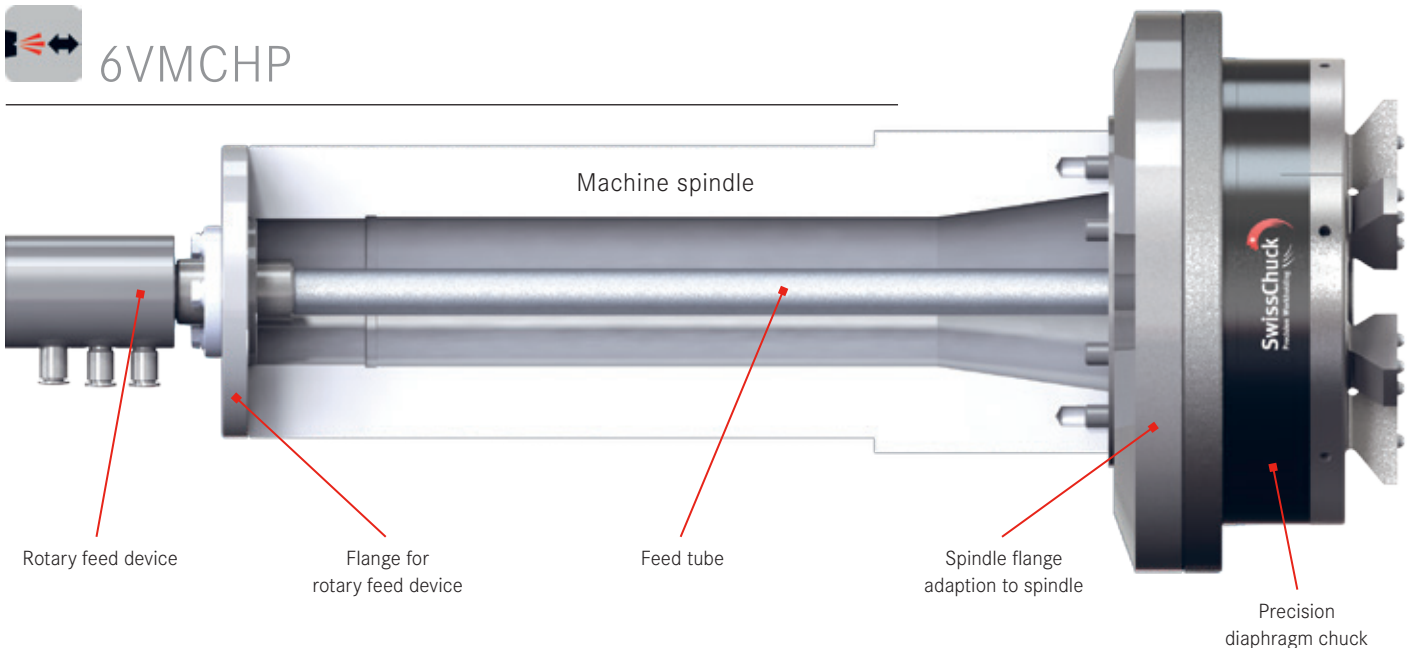

The chuck is specifically mounted according to the machine type, SwissChuck designs and provides all the required components. Hence, our customers will receive the entire workholding unit ready for installation.



KCHP/VKHP
High-precision force chuck

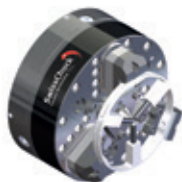

SAP to KCHP
Automated drive carrier



KFHP
Precision power chuck



KHSF
Centrifugal force chuck



VMCHP
Diaphragm chuck

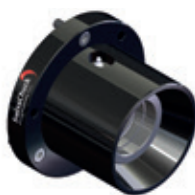

LZK/LSK-S
Collet chuck with clamping lamellas



DL
Collet expanding mandrel



TGC/FTGC
Tool chuck

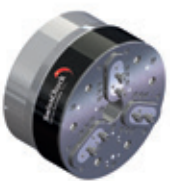

OVEK
High-precision force chuck



OVEKA
Compensating chuck

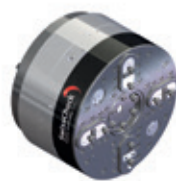

OVEKAV
Moving compensating chucks

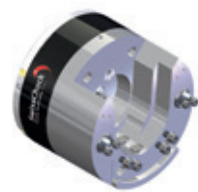

FLD/AFLD
Twist finger type console chuck



SPECIAL SOLUTIONS
Tailor made solutions

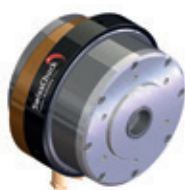

PZLHM
Pneumatic force clamping cylinder

SwissChuck AG
Industriestrasse 3
CH-8307 Effretikon
P +41 52 355 31 31
F +41 52 343 52 40
SwissChuck.com



Service@SwissChuck.com



Sales@SwissChuck.com

