

**NEW**  
GENERATION



PRECISION POWER CHUCK  
KCHP/VKCHP



# PRECISION POWER CHUCK

The KCHP/VKCHP precision power chucks have been specifically designed for cylindrical grinding machines. To ensure a flawless long-term operation, the chucks are hermetically sealed against contamination and are oil-filled for permanent lubrication. These design features render the chucks nearly maintenance-free. All the precision power chucks of the generation KCHP/VKCHP now also feature volume compensation to prevent unwanted loss of oil and ingress of coolant.

The KCHP power chucks are actuated via a drawbar and a pneumatic cylinder mounted at the back of the machine spindle. The power chucks VKCPH are actuated via a rotating air tube through the spindle bore. For this reason, there is no need for mounting a pneumatic cylinder at the back of the headstock spindle.

## Changing of jaws within micrometer tolerances made easy!

All power chucks of the KCHP/VKCHP generation feature precision jig-ground locating bores for precision ball positioning. This ensures a quick clamping jaw change, independent of the chuck, and without any need of regrinding. This saves valuable time and increases productivity. Under optimal conditions, the jaws can be changed within an accuracy of  $\leq 0.002$  mm.

### Advantages



- High precision  $\leq 0.002$  mm
- Sealed, suitable for grinding machines
- Lightweight design
- Precision interfaces between base and top jaws
- Low on maintenance
- Possible to interchange jaws between chucks of identical design

### Function



- OD and ID clamping
- Large central bore (through hole)
- Power chuck (KCHP) for actuation by means of a pneumatic cylinder
- Power chuck (VKCHP) pneumatically actuated on front-end
- Ideal chucks for all cylindrical grinding machines

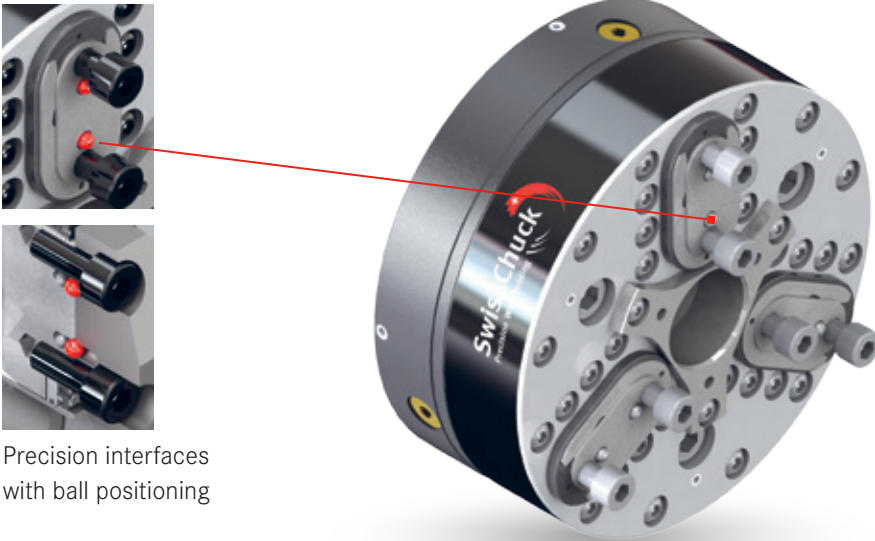

Precision interfaces  
with ball positioning

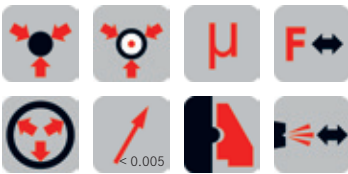

Explanation of symbols:  
SwissChuck.com

Suitability according  
to machining process:

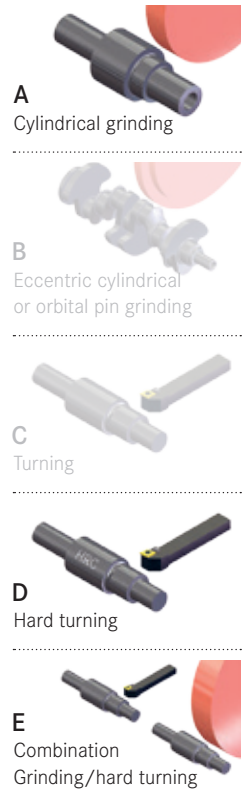

## KCHP / KFHP

Type	Item number	ø Size [mm]	Height [mm]	ø Through bore [mm]	Clamping force max. [kN]	Max. RPM [1/min]	Jaw stroke radial [mm]	Weight [kg]	Suitable for
3KCHP 110	SX1018218	110	52	12	9	3000	1.25	2.2	A(DE)
3KCHP 130	SX1018220	130	52	22	9	2500	1.5	2.9	A(DE)
3KCHP 160	SX1018222	160	60	30	13	2250	2.5	4.9	A(DE)
3KCHP 200	SX1018224	198	62	40	13	2000	2.5	7.4	A(DE)
3KCHP 250	SX1018226	250	69	52	13	1500	2.5	12.8	A(DE)
3KFHP 315	SX1013257	315	66	48	18	500	4.0	35.5	A(DE)
3KFHP 355	SX1013256	355	66	88	18	500	4.0	40.5	A(DE)
3KFHP 400	SX1013252	400	66	120	18	500	4.0	57.5	A(DE)

## VKCHP

Type	Item number	ø Size [mm]	Height [mm]	Bore [mm]	Clamping force max. [kN]	Max. RPM [1/min]	Jaw stroke radial [mm]	Weight [kg]	Suitable for
3VKCHP 110	SX1018219	110	68.5	ø12 to 36 deep	2.5	2500	1.25	3.3	A(DE)
3VKCHP 130	SX1018221	130	70	ø22 to 34 deep	4.0	2500	1.5	4.6	A(DE)
3VKCHP 160	SX1018223	160	80	ø30 to 40 deep	6.5	2250	2.5	7.6	A(DE)
3VKCHP 200	SX1018225	198	82	ø40 to 40 deep	10.0	2000	2.5	11.7	A(DE)
3VKCHP 250	SX1018227	250	69	ø52 to 45 deep	12.0	1500	2.5	21.1	A(DE)

# EXAMPLES OF APPLICATIONS

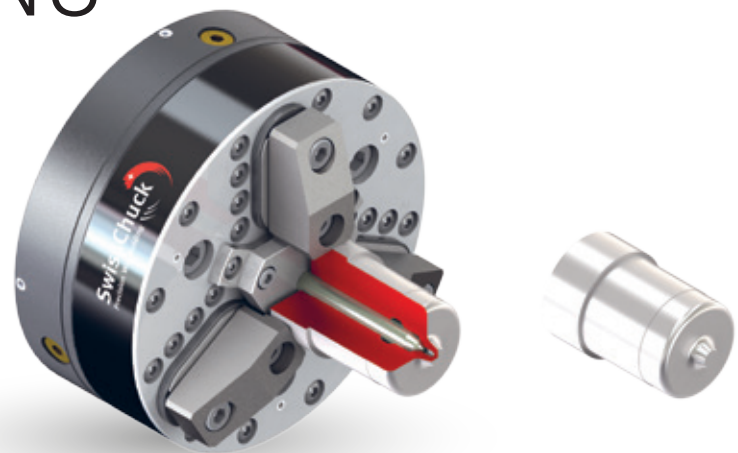

## 3KCHP 160

---

### Fuel injection nozzle body:

#### Clamping of nozzle body with axial end-stop against the bore taper

- Grinding of the nozzle body's nose
- Axial end-stop on tungsten carbide pin
- Concentric clamping on OD

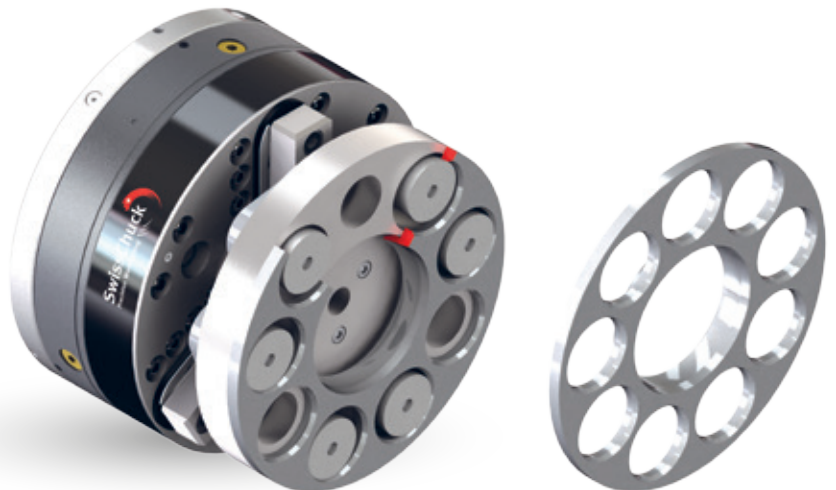

## 3VKCHP 200

---

### Distribution disk:

#### Internal clamping of distribution disks of hydraulic motors

- Grinding of the face and the concentric bore
- Low-deformation radial clamping in six bores
- Compensation by means of pendulum jaws
- Rigid axial end-stop for achieving a maximum flatness on the face

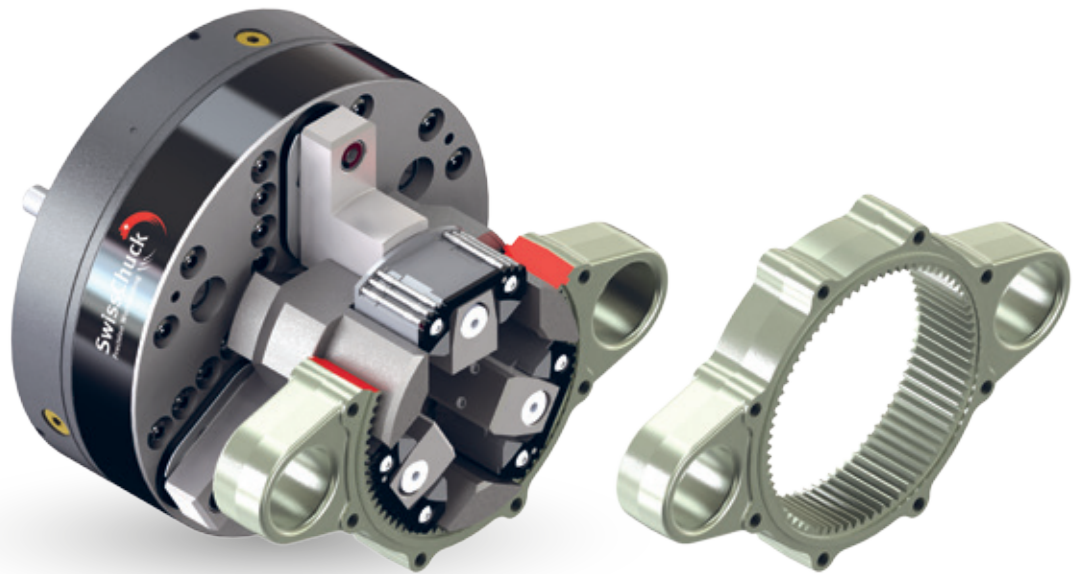

## 3KCHP 200

### Ring gear with internal teeth:

#### Clamping in the pitch circle of the internal gear teeth

- Grinding of the face and the centering bores
- Low-deformation positioning within the pitch circle diameter
- Compensation by means of pendulum jaws fitted with clamping pins for positioning within the pitch circle

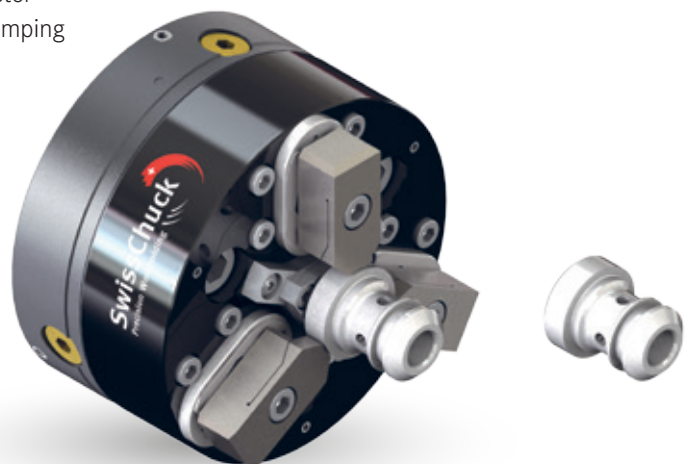

## 3KCHP 110

### Valve body:

#### Outside clamping with pull-back onto axial end-stop

- Grinding of the bore and the outer front section
- Rigid clamping by means of part pull-back onto axial end-stop
- High concentricity and tight tolerances on the linear measurement

# EXAMPLES OF APPLICATIONS



## SAP 160

---

### Valve

#### Compensating clamping between centers

- Cylindrical grinding of the valve shaft and head
- No deflection of the shaft allowed
- Sufficient torque transmission for OD grinding



## SAP 160 So

---

### Spline shaft:

#### Compensating clamping between centers

- Cylindrical grinding of various outside diameters
- High concentricity
- Free of distortion - free of lateral loads
- No need for changeover to a compensating chuck

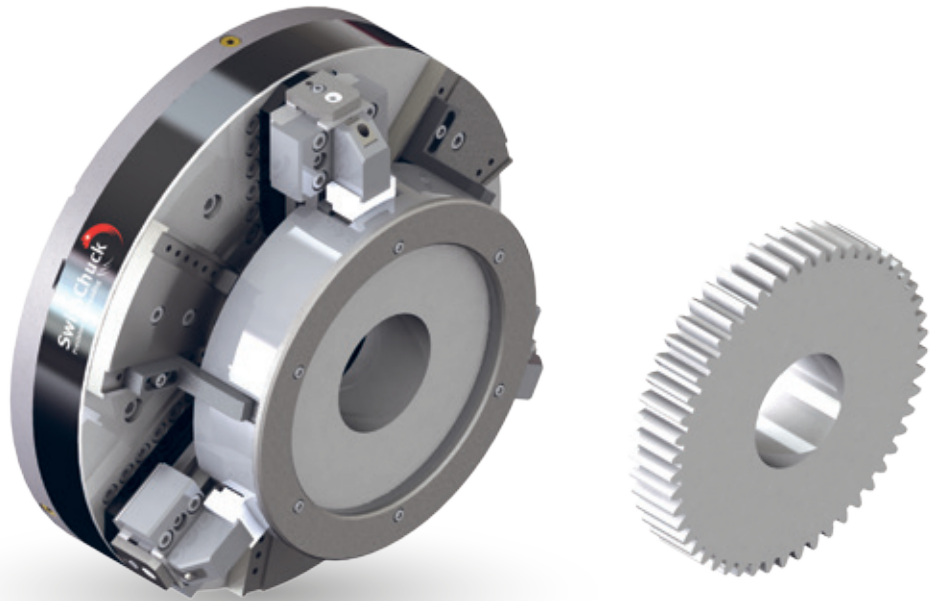

## 3KFHP 400

---

**Gear part:**

**Clamping of gears on pitch circle (approx.  $\varnothing 250$ )**

- Grinding of the bore
- High concentricity required
- Workpiece is first inserted into a needle cage and subsequently this assembly is clamped in chuck

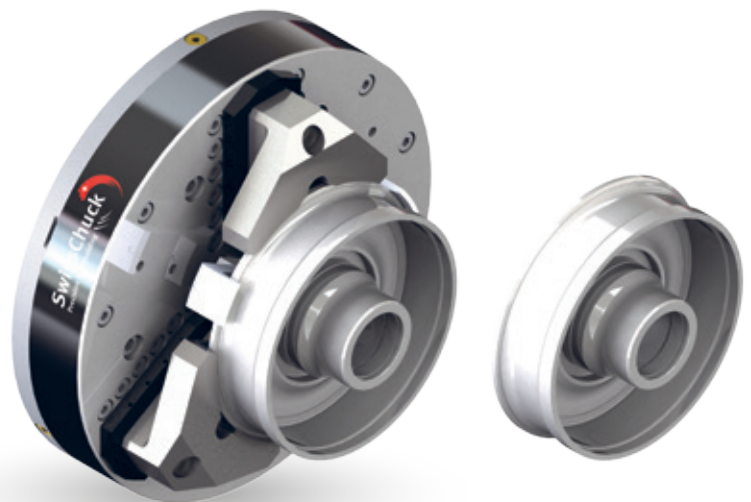

## 3KFHP 315

---

**Part of CVT gearbox:**

**Clamping on OD diameter**

- Grinding of face and ID diameters
- Must be free of deformation caused by clamping force
- High concentricity and axial run-out accuracy

# ACCESSORIES

## KCHP / VKCHP

Standard range of soft top jaws and of segment jaws

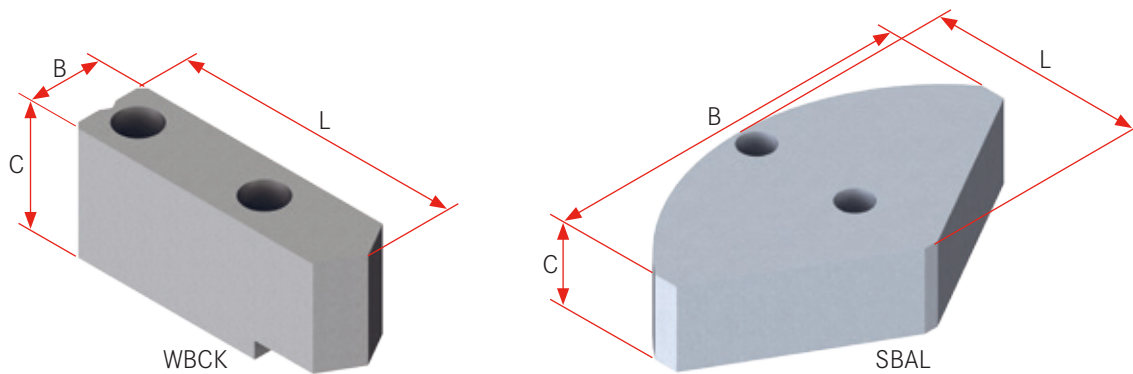

Type of chuck	Size	Designation	Item number	Type of jaws	Width B [mm]	Height C [mm]	Length L [mm]	Material
KCHP / VKCHP	110	KCHP-WBCK 110	CHM300251	soft top jaws	on request	on request	on request	on request
	130	KCHP-WBCK 130	CHM38758					
	160	KCHP-WBCK 160	CHM38746					
	200	KCHP-WBCK 200	CHM39069					
	250	KCHP-WBCK 250	CHM38752					
KFHP	315	KFHP-WBCK 315		soft top jaws	on request	on request	on request	on request
	355	KFHP-WBCK 355						
	400	KFHP-WBCK 400						
KCHP / VKCHP	110	KCHP-SBAL 110	CHM300403	segment jaws	on request	on request	on request	on request
	130	KCHP-SBAL 130	CHM38759					
	160	KCHP-SBAL 160	CHM38747					
	200	KCHP-SBAL 200	CHM39070					
	250	KCHP-SBAL 250	CHM24790					
KFHP	315	KFHP-SBAL 315		segment jaws	on request	on request	on request	on request
	355	KFHP-SBAL 355						
	400	KFHP-SBAL 400						

Soft top jaws made of CK 45 steel or segment jaws made of aluminum for the 3KCHP / 3VKCHP range of chucks are available as a standard option. Special dimensions can be made on request. Special top jaws, also in hardened steel, can be designed according to the application and will be supplied either pre-ground or finish-ground.



## KCHP-SF: simultaneous chuck

As a rule, before the clamping areas of soft top jaws can be ground, they must first be turned. The advantage offered by a simultaneous chuck is that the main chuck can remain on the grinding machine while the jaws can be mounted on a simultaneous chuck. This chuck can subsequently be clamped in a three-jaw chuck or in a magnetic chuck on a lathe.

The simultaneous chucks are fitted with three jaw mounting locations for both ID and OD clamping in such a way that the top jaws can be machined at the clamping section while correctly taking the clamping stroke into account.

Type of chuck	Item number	Designation
3KCHP 110 / 3VKCHP 110	CHZ300401	3KCHP-SF 110
3KCHP 130 / 3VKCHP 130	CHZ38952	3KCHP-SF 130
3KCHP 160 / 3VKCHP 160	CHZ38953	3KCHP-SF 160
3KCHP 200 / 3VKCHP 200	CHZ24943	3KCHP-SF 200
3KCHP 250 / 3VKCHP 250	CHZ25659	3KCHP-SF 250
3KFHP 315		3KFHP-SF 315
3KFHP 355		3KFHP-SF 355
3KFHP 400		3KFHP-SF 400



## KCHP-VSA: preload disks for OD clamping

Preload disks are placed between the top jaws. Subsequently, the chuck is actuated with an applied preload. This allows that the clamping sections can be ground while a preload is applied.

Type of chuck	Item number	Designation	Steps in $\varnothing$	Number
3KCHP 110 / 3VKCHP 110	CHZ300404	3KCHP-VSA 110	0.25 mm	8
3KCHP 130 / 3VKCHP 130	CHZ38757	3KCHP-VSA 130	0.25 mm	11
3KCHP 160 / 3VKCHP 160	CHZ38748	3KCHP-VSA 160	0.25 mm	17
3KCHP 200 / 3VKCHP 200	CHZ39071	3KCHP-VSA 200	0.25 mm	17
3KCHP 250 / 3VKCHP 250	CHZ38755	3KCHP-VSA 250	0.25 mm	17

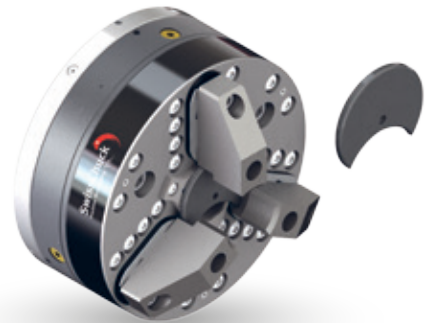

## KCHP-VSI: preload ring for ID clamping

The preload ring is mounted with the matching cylindrical pins as shown in the illustration on the right. The top jaws for ID clamping are subsequently preloaded towards the outside. This allows that the clamping sections can be ground while a preload is applied.

Type of chuck	Item number	Designation	Steps in $\varnothing$
3KCHP 110 / 3VKCHP 110	CHZ300405	3KCHP-VSI 110	0.5 mm
3KCHP 130 / 3VKCHP 130	CHZ38760	3KCHP-VSI 130	0.5 mm
3KCHP 160 / 3VKCHP 160	CHZ24786	3KCHP-VSI 160	0.5 mm
3KCHP 200 / 3VKCHP 200	CHZ24942	3KCHP-VSI 200	0.5 mm
3KCHP 250 / 3VKCHP 250	CHZ24788	3KCHP-VSI 250	0.5 mm



# ACCESSORIES SAP

## SAP Standard | Compensating clamping between centers

The concentric chucks of Type 3KCHP can be «converted» into a compensating chuck by using an SAP kit. This allows the machining between centers of critical shaft-type workpieces. The floating clamping ring ensures that the workpieces are not subject to any deformation due to clamping forces.

A further advantage offered by this arrangement is that the concentric chucks do not have to be dismantled and replaced by a standard compensating chuck.

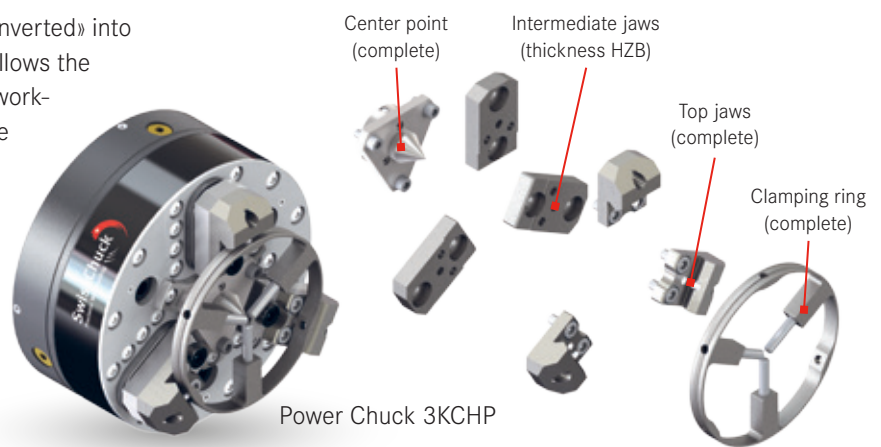

Type of chuck	Clamping ring (complete) Item number	Designation	Center point (complete)	Clamping ring (complete)	Top jaw (complete)	Intermediary jaw with thickness HZB	Clamping $\phi$ max. [mm]	Clamping force *** [kN]
3KCHP 110	CHZ25744	SAP 110	SX1003217	SX1003218	SX1003173	CHM300639-HZB	32	1.0 - 1.5
3KCHP 130	CHZ24944	SAP 130	CHY304423	SX1001386	SX1003216	CHM39597-HZB	50	1.0 - 2.5
3KCHP 160	CHZ24945	SAP 160	CHY304195	SX1001386	SX1001365	CHM39542-HZB	50	1.0 - 2.5
3KCHP 200	CHZ24946	SAP 200	CHY304196	CHY25355-01	CHY39691	CHM39693-HZB	50	2.0 - 5.0
3KCHP 200	CHZ24946	SAP 200	CHY304196	CHY25355-02	CHY39691	CHM39693-HZB	100	2.0 - 5.0
3KCHP 250	CHZ25662	SAP 250	SX1003228	CHY25355-01	CHY39691	CHM300408-HZB	50	2.0 - 5.0
3KCHP 250	CHZ25662	SAP 250	SX1003228	CHY25355-01	CHY39691	CHM300408-HZB	100	2.0 - 5.0

\*\*\* The clamping force is inversely proportional to the opening stroke, which can be flexibly set

When placing an order, the thickness HZB of the intermediary jaws must be specified.

The application of the SAP can only be used in conjunction with a 3KCHP chuck which is actuated by a pneumatic cylinder. Front-end actuated chucks of the 3VKCHP type can open the clamping ring only insufficiently or not at all.

## SAP Special Solutions

Special solutions can be designed for applications with specific requirements. In this way, for example, higher clamping forces could be achieved.

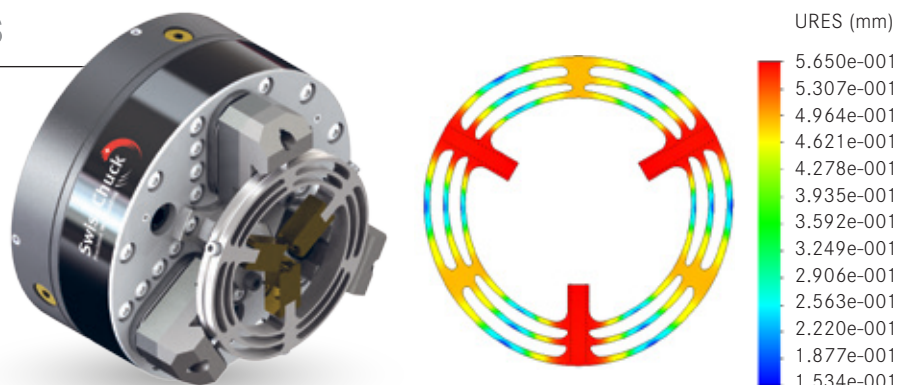

## MOUNTING EXAMPLES



3VKCHP

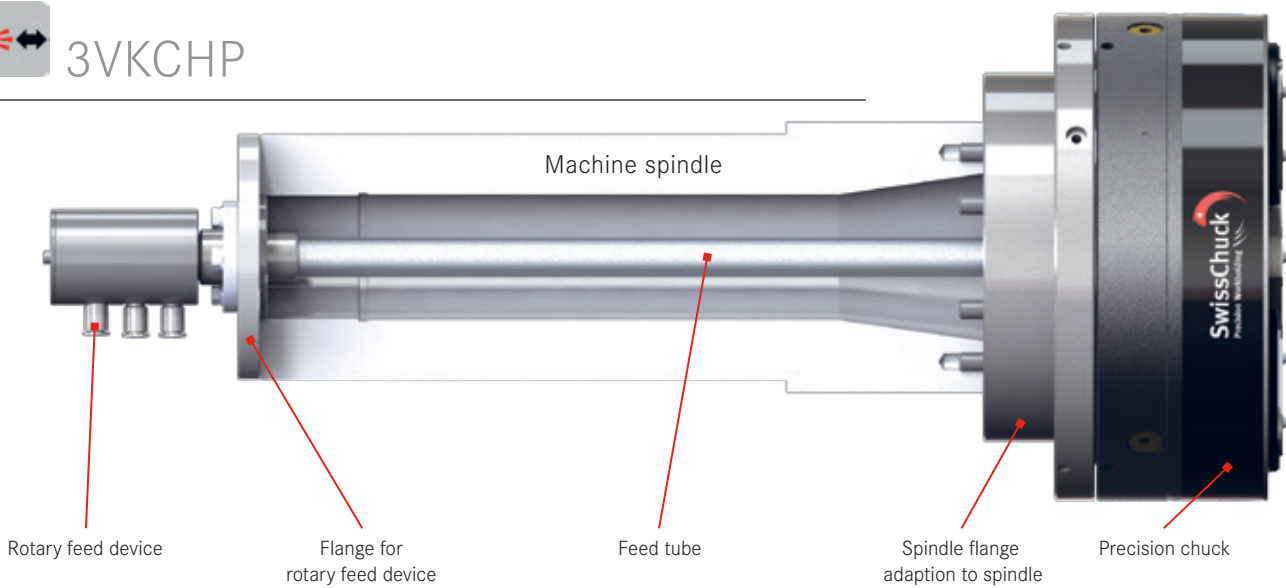

3KCHP

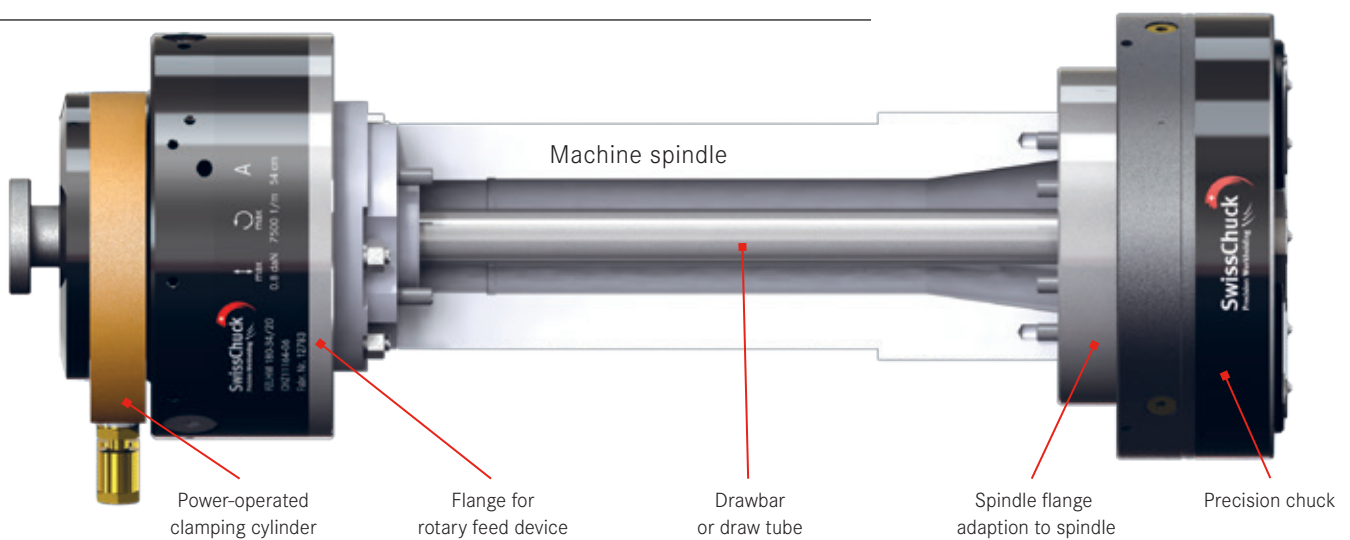

The chuck is specifically mounted according to the machine type, SwissChuck designs and provides all the required components. Hence, our customers will receive the entire workholding unit ready for installation.



**KCHP/VKHP**  
High-precision force chuck

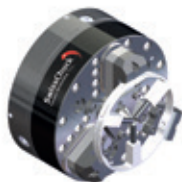

**SAP to KCHP**  
Automated drive carrier

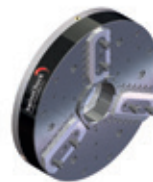

**KFHP**  
Precision power chuck



**KHSF**  
Centrifugal force chuck



**VMCHP**  
Diaphragm chuck

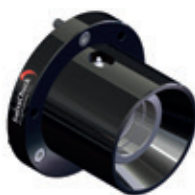

**LZK/LSK-S**  
Collet chuck with clamping lamellas



**DL**  
Collet expanding mandrel



**TGC/FTGC**  
Tool chuck

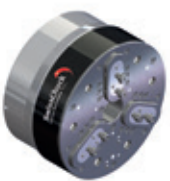

**OVEK**  
High-precision force chuck



**OVEKA**  
Compensating chuck

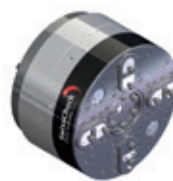

**OVEKAV**  
Moving compensating chucks

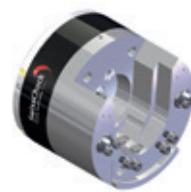

**FLD/AFLD**  
Twist finger type console chuck



**SPECIAL SOLUTIONS**  
Tailor made solutions

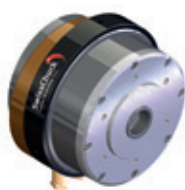

**PZLHM**  
Pneumatic force clamping cylinder

SwissChuck AG  
Industriestrasse 3  
CH-8307 Effretikon  
P +41 52 355 31 31  
F +41 52 343 52 40  
SwissChuck.com



[Service@SwissChuck.com](mailto:Service@SwissChuck.com)



[Sales@SwissChuck.com](mailto:Sales@SwissChuck.com)

