

FINE FILTRATION SYSTEM CORE 800 MAXI with IFDR technology

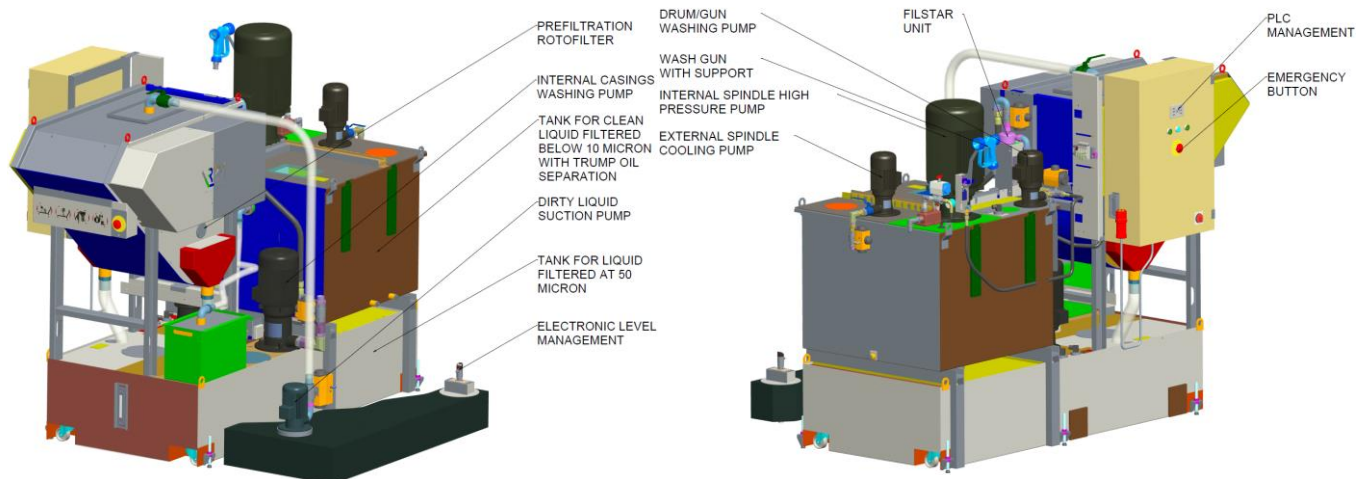

Advantages of CORE 800 MAXI

The CORE fine filtration system has been designed to provide a solution to problematic situations that are frequently found on machine tools. Moreover, it can be installed on new machines fitted with tanks and conveyors with unsuitable features for specific work.

In particular, it offers answers to the following problems:

- Presence of small chips in the tank with frequent pump clogging.
- Presence of floating oils, which prevent proper oxygenation, on the coolant surface.
- Need for less than 10 μm filtration degree for coolant to be sent to the machine tool spindle.

The CORE 800 MAXI fine filtration system integrates three widely tested technologies in the RBM's constructive tradition, and precisely:

- The technology of our rotofilters with stainless steel drum and **prefiltration at 50 μm** .
- The FILSTAR technology – **no filter elements to be replaced and disposed of** – to guarantee **fine filtration below 10 μm** .
- IFDR technology to guarantee the **dynamic separation of the oil** and the correct oxygenation of the coolant.

The simplicity of assembly and functional management managed by an integrated PLC make this solution extremely various and applicable to any machine tool.

Approval to the Machinery Directive and CE certification as a machine.

TECHNICAL FEATURES

Overall system volume	950 L
Processing flow rate 50 μm	From 250 to 350 L/min
Processing flow rate 10 μm	120 L/min
Coolant type	Both synthetic and mineral coolant
Filstar unit	KM32
Clean coolant volume	500 L
Nominal factory space requirements (LxWxH)	2545 x 1302 x 2072 mm
Nominal empty weight	1.086 kg
Automatic sludge recovery	In a special tank
Dynamic separation of the oil	Automatic integrated
Dirty liquid suction pump	Standard
Electrical control panel with machine tool interface	Standard
Working cycle	Continuous 24/7
Guaranteed filtration degree	Below 50 μm for 100% of the coolant
Guaranteed filtration degree	Below 10 μm for delivery pumps
Chiller for temperature control	Optional
Automatic coolant top up	Integrated

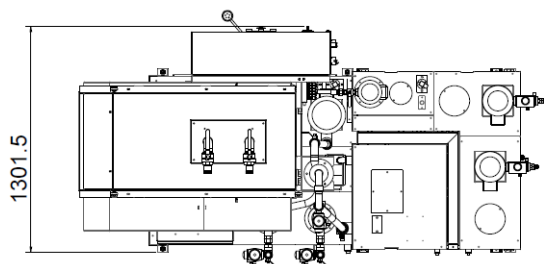
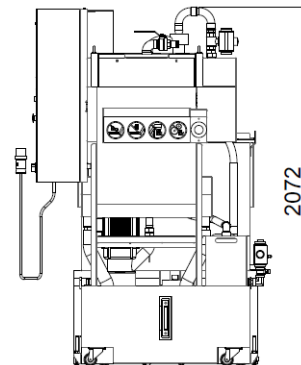
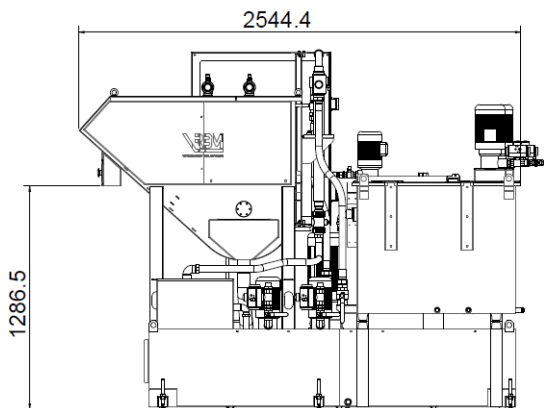

RBM International S.r.l.

Via Roma, 9/C – 33040 Pradamano (UD) – Italy

Tel. +39 0432 671504 – F. +39 0432 671608

VAT Nr. IT 02081310308 – C.C.I.A. Udine REA n. 233907 – Capitale sociale € 52.000

rbminternational@machinerbm.com – www.machinerbm.com